



UL LED EMERGENCY DRIVERS

USA QuickShip program



FC RoHS

americanlite[®]
We light your world[™]

BLEDEM-BP/DM-20

EMERGENCY DRIVER FOR LED LAMPS (WITH INTERNAL / EXTERNAL DRIVER)



STANDARD



ILLUMINATION

- Provides 180-320VDC (equals to 120-230VAC) to the load during emergency mode operation.
- For use with switched or unswitched fixtures.
- Can be used with LED lamp loads of up to 20W and provide 100% lumen output.

ELECTRICAL

- Universal 120-277V, 50-60 Hz input.
- Charge/Power "ON" LED indicator light and push-to-test switch for mandated code compliance testing.
- Long-life, maintenance free, rechargeable NiCad battery.
- Output short/overcurrent protection: Electronic limiting, with normal operation resuming upon removal of fault.
- 90 Minute minimum emergency operating time over full temperature range.
- 24 Hour maximum battery recharge time.

HOUSING

- Durable painted steel construction in red finish.
- Provided with 2' flex conduits.

MOUNTING

- Suitable for installation on top or in remote of the fixture.
- Can be used in both switched and unswitched fixtures.

WARRANTY/LISTING

- UL Listed for factory or field installation.
- Suitable for damp locations (0°C - 50°C).
- 5 year warranty on all electronics and housing.
- Meets UL924, NFPA 101 Life Safety Code, NEC, OSHA, Local and State codes.

DIMENSIONS

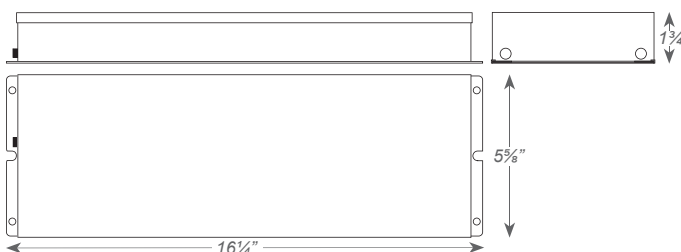

WIRING DIAGRAM

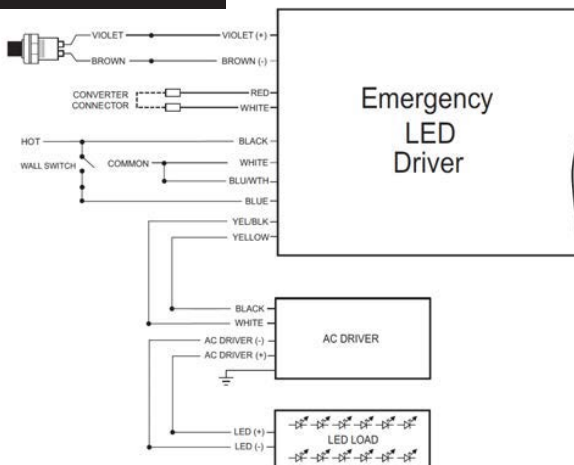

ORDERING INFORMATION

MODEL	OUTPUT RATINGS	
	VOLTAGE (VDC)	POWER (W)
BLEDEM-BP/DM-20	180-320	20

BLEM-CP-CW

Constant-Power Outdoor-rated Emergency LED Driver

STANDARD



ILLUMINATION

- Provides constant power output to the load during emergency mode operation.
- Can be operated as NORMALLY-ON, NORMALLY-OFF or SWITCHED LOAD.
- Ideal for use with canopy lights, garage lights and any outdoor fixture that needs emergency lighting.

ELECTRICAL

- Universal 120-277V, 50/60 Hz input.
- Charge/Power "ON" LED indicator light and push-to-test switch for mandated code compliance testing.
- Long-life, maintenance free, rechargeable NiCad battery.
- Output short/overcurrent protection: Electronic limiting, with normal operation resuming upon removal of fault.
- 90 minutes minimum emergency operating time over full temperature range.
- Output classification: Class 2 Compliant.
- Surge protection: Per C62.41 (TVS).
- Input overcurrent protection: Fusible link.
- 24 Hour maximum battery recharge time.

HOUSING

- Decorative, low profile, architectural design.
- Die-cast aluminum housing.
- Durable powder-coated bronze finish.
- Sealed and gasketed.

MOUNTING

- Suitable for installation as top, or side mount of the fixture.

WARRANTY/LISTING

- UL Classified for factory or field installation.
- Suitable for wet locations (-20°C - 50°C).
- 5 year warranty on all electronics and housing.
- Meets UL924, NFPA 101 Life Safety Code, NEC, OSHA, Local and State codes.
- Certified to CEC under Title 20 regulations.

DIMENSIONS

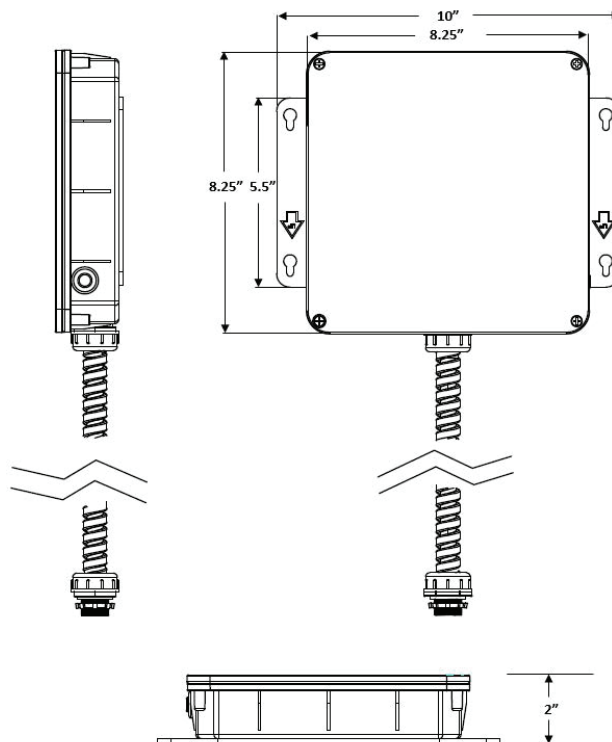

ORDERING INFORMATION

Lumen output based on LED light source having efficacy of 160 lumens/watt. Actual output may vary depending on light source utilized.

Provides regulated power to 17.0 watts (2400 lumens)

MODEL	OUTPUT OPERATING RANGE		OUTPUT POWER	
	VOLTAGE (Vdc)	CURRENT (mAdc)	(Watts)	(Lumens)
BLEM-CP-CW	20-50	850-340	17.0	2400

BLEM-CP-CW

Constant-Power Outdoor-rated Emergency LED Driver

ELECTRICAL INFORMATION

MODEL	INPUT CURRENT (A)	INPUT POWER (W)
BLEM-CP-CW	0.11	7.9

WIRING DIAGRAM

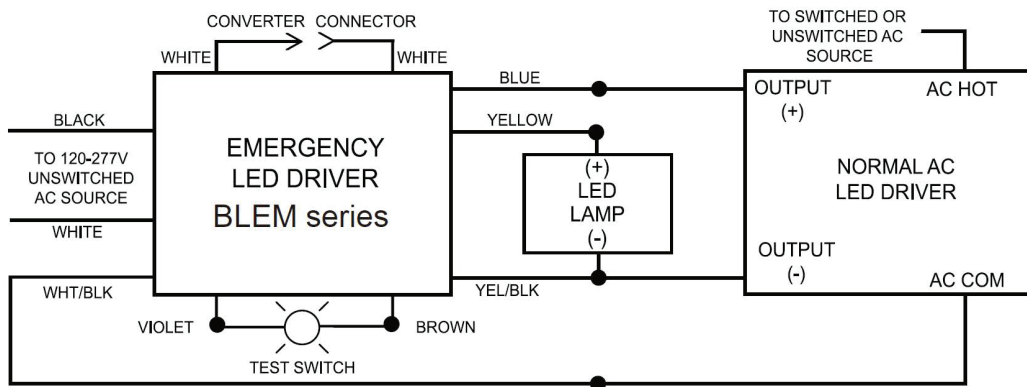

BLEM-CP-CW Series System Coordination Guidelines

These guidelines were developed to allow the lighting system Designer/Specifier to predict the operating performance levels of LED luminaires when powered by an electrically compatible BLEM-CP-CW Series model. It is ultimately the responsibility of the Designer/Specifier to insure that the as installed system delivers code-compliant path of egress illumination.

1) Determine Electrical Compatibility

- Verify that the Luminaire LED Driver, where applicable, is Class 2 compliant.
- Verify that the Luminaire LED Lamp(s) have an operating voltage between 20Vdc and 50Vdc range.
- Verify that the Luminaire LED Lamp(s) have a power rating equal to, or greater than 17 watts (emergency power rating of the BLEM-CP-CW driver).

2) Calculate Lumen Output During Emergency Operation

- Access luminaire data by logging onto Design Lites Consortium (www.designlights.org).
- Select "Search the DLC Qualified Product List" on the DLC homepage.
- Enter manufacturer name and P/N of luminaire under consideration in the "search by keyword" text window.
- Select "Search" tab to open the "Qualified Products List".
- Determine luminaire Lumens per Watt efficacy in "Rated Data" specifications.
- Multiply luminaire Lumens per Watt by 17 (output power of BLEM-CP-CW driver). This figure is the Lumens available from the luminaire during emergency operation.

3) Determine Suitability of Means of Egress Lighting Levels

- Using industry standard lighting design software, along with IES files for the luminaire under consideration, verify that the as installed available Lumens (as calculated in 2F above) are sufficient to meet Code-compliant path of egress illumination levels.

While the BLEM-CP-CW series has been found compliant with the requirements of UL Standard 924, it is ultimately the responsibility of the Designer/Specifier to ensure the as-installed system delivers code-compliant path of egress illumination in accordance with Federal, State or local municipal requirements.

BLEM-CP

CONSTANT-POWER EMERGENCY LED DRIVER with & without conduit

STANDARD



ILLUMINATION

- Works with or without an AC driver to convert new or existing LED fixtures into unobtrusive emergency lighting.
- Provides constant power output to the load during emergency mode operation.
- Designed to operate NORMALLY-ON, NORMALLY-OFF or SWITCHED LOAD fixtures.

ELECTRICAL

- Universal 120-277V, 50/60 Hz input.
- Charge/Power "ON" LED indicator light and push-to-test switch for mandated code compliance testing.
- Long-life, maintenance free, rechargeable Lithium Iron Phosphate battery.
- Output short/overcurrent protection: Electronic limiting, with normal operation resuming upon removal of fault.
- 90 Minute minimum emergency operating time over full temperature range.
- Output classification: Class 2 Compliant.
- Surge protection: Per C62.41 (TVS).
- Input overcurrent protection: Fusible link.
- 24 Hour maximum battery recharge time.

HOUSING

- LED illuminated and remote mounted test switch.
- Low profile galvanized steel construction.
- Compact design allows for installation of non-conduit models, inside most LED fixtures.

MOUNTING

- Suitable for inside (standard models only), top or in remote* (conduit models) of the LED fixture

WARRANTY/LISTING

- UL Listed for factory or field installation.
- Suitable for damp locations (10°C - 55°C).
- 5 year warranty on all electronics and housing.
- Meets UL924, NFPA 101 Life Safety Code, NEC, OSHA, Local and State codes.
- Certified to CEC under Title 20 regulations.

DIMENSIONS

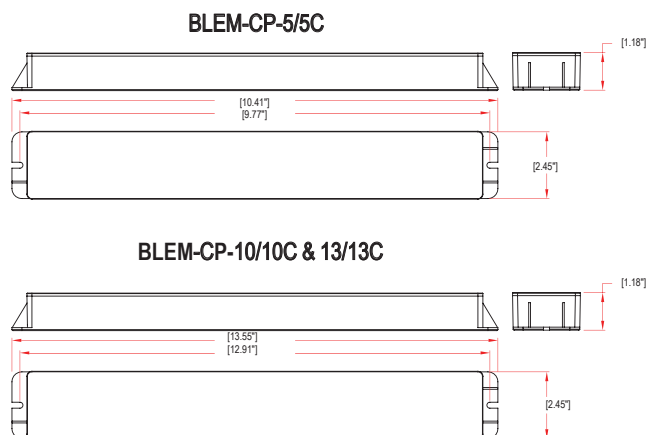

ORDERING INFORMATION

Sample Part Number: **BLEM-CP-5C**

MODEL	OUTPUT POWER	OPTIONS
BLEM-CP	5 5.0 Watts	C with 2-ft conduit on both ends
	10 10.7 Watts	
	13 13.7 Watts	

* When battery packs are remote-mounted, the remote distance cannot exceed 1/2 of the distance from driver to LED load specified by the A.C. driver manufacturer. The maximum allowable remote mounting distance is 20 feet.

BLEM-CP

CONSTANT-POWER EMERGENCY LED DRIVER with & without conduit

ELECTRICAL INFORMATION

MODEL	INPUT CURRENT (A)	INPUT POWER (W)	OUTPUT VOLTAGE (V)	OUTPUT POWER (W)	OUTPUT CURRENT (mA)
BLEM-CP-5/5C	0.061	3.9	20-50	5.0	250-100
BLEM-CP-10/10C	0.087	5.7	20-50	10.7	535-214
BLEM-CP-13/13C	0.110	6.9	20-50	13.7	685-214

WIRING DIAGRAM

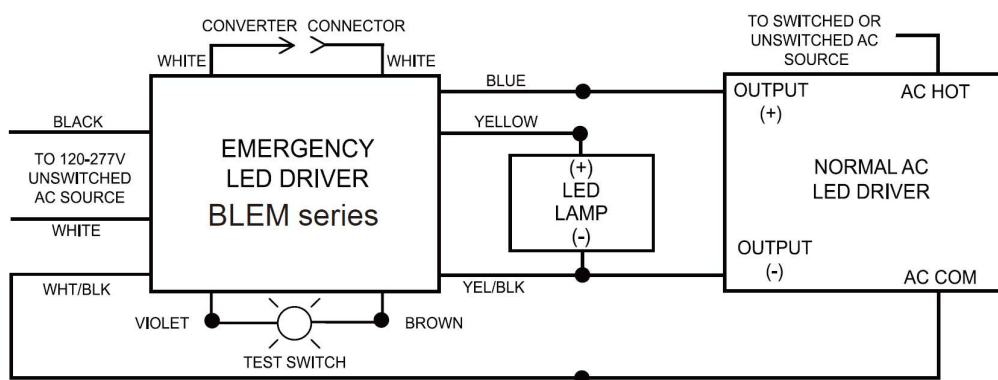

BLEM-CP Series System Coordination Guidelines

These guidelines were developed to allow the lighting system Designer/Specifier to predict the operating performance levels of LED luminaires when powered by an electrically compatible BLEM-CP series model. It is ultimately the responsibility of the Designer/Specifier to ensure that the as installed system delivers the code-compliant path of egress illumination.

1) Determine Electrical Compatibility

- Verify that the Luminaire LED Driver, where applicable, is Class 2 compliant.
- Verify that the Luminaire LED Lamp(s) have an operating voltage between 20Vdc and 50Vdc range.
- Verify that the Luminaire LED Lamp(s) have a power rating equal to, or greater than, the emergency power rating of the BLEM-CP model under consideration (refer to the Electrical Information section).

2) Calculate Lumen Output During Emergency Operation

- Access luminaire data by logging onto Design Lites Consortium (www.designlights.org).
- Select "Search the DLC Qualified Product List" on the DLC homepage.
- Enter manufacturer name and P/N of luminaire under consideration in the "search by keyword" text window.
- Select "Search" tab to open the "Qualified Products List".
- Determine luminaire Lumens per Watt efficacy in "Rated Data" specifications.
- Multiply luminaire Lumens per Watt by Emergency Output of the BLEM-CP model under consideration (refer to the Electrical Information section). This figure is the Lumens available from the luminaire during emergency operation.

3) Determine Suitability of Means of Egress Lighting Levels

- Using industry standard lighting design software, along with IES files for the luminaire under consideration, verify that the as installed available Lumens (as calculated in 2F above) are sufficient to meet Code-compliant path of egress illumination levels.

While the BLEM-CP series has been found compliant with the requirements of UL Standard 924, it is ultimately the responsibility of the Designer/Specifier to ensure the as-installed system delivers code-compliant path of egress illumination in accordance with Federal, State or local municipal requirements.

BLEMLP-CP

Low-Profile Constant-Power Emergency LED Driver

STANDARD



ILLUMINATION

- Works with or without an AC driver to convert new or existing LED fixtures into unobtrusive emergency lighting.
- Provides constant power output to the load during emergency mode operation.
- Designed to operate NORMALLY-ON, NORMALLY-OFF or SWITCHED LOAD fixtures.

ELECTRICAL

- Universal 120-277V, 50/60 Hz input.
- Charge/Power "ON" LED indicator light and push-to-test switch for mandated code compliance testing.
- Long-life, maintenance free, rechargeable lithium iron phosphate battery.
- Output short/overcurrent protection: Electronic limiting, with normal operation resuming upon removal of fault.
- 90-minute minimum emergency operating time over full temperature range.
- Output classification: Class 2 Compliant.
- Surge protection: Per C62.41 (TVS).
- Input overcurrent protection: Fusible link.
- 24 hour maximum battery recharge time.

HOUSING

- LED illuminated test switch.
- Low-profile, slender galvanized steel housing.
- Compact design allows for installation inside most linear LED fixtures.

MOUNTING

- Suitable for installation inside linear LED fixtures.

WARRANTY/LISTING

- UL Listed for factory or field installation.
- Suitable for damp locations (10°C - 55°C).
- Five year warranty on all electronics and housing.
- Meets UL924, NFPA 101 Life Safety Code, NEC, OSHA, Local and State codes.
- Certified to CEC under Title 20 regulations.

DIMENSIONS

BLEMLP-CP-10 & 13

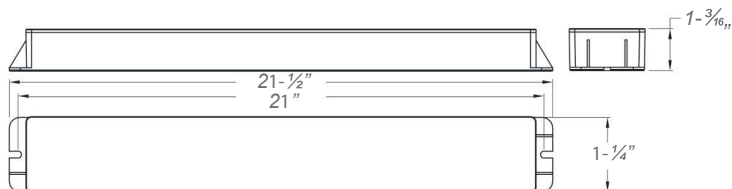

ORDERING INFORMATION

Sample Part Number: **BLEMLP-CP-10**

MODEL	OUTPUT POWER	
	BLEMLP-CP-10	-10
	-13	13.7 Watts

BLEMLP-CP

Low-Profile Constant-Power Emergency LED Driver

ELECTRICAL INFORMATION

MODEL	INPUT CURRENT (A)	INPUT POWER (W)	OUTPUT VOLTAGE (V)	OUTPUT POWER (W)	OUTPUT CURRENT (mA)
BLEMLP-CP-10	0.087	5.7	20-50	10.7	535-214
BLEMLP-CP-13	0.110	6.9	20-50	13.7	685-274

Coordination Guidelines

These guidelines were developed to allow the lighting system Designer/Specifier to predict the operating performance levels of LED luminaires when powered by an electrically compatible emergency driver. It is ultimately the responsibility of the Designer/Specifier to ensure that the as installed system delivers the code-compliant path of egress illumination.

1) Determine Electrical Compatibility

- A) Verify that the Luminaire LED Driver, where applicable, is Class 2 compliant.
- B) Verify that the Luminaire LED Lamp(s) have an operating voltage between 20Vdc and 50Vdc range.
- C) Verify that the Luminaire LED Lamp(s) have a power rating equal to, or greater than, the emergency power rating of the emergency driver under consideration (refer to the Electrical Information section).

2) Calculate Lumen Output During Emergency Operation

- A) Access luminaire data by logging onto Design Lites Consortium (www.designlights.org).
- B) Select "Search the DLC Qualified Product List" on the DLC homepage.
- C) Enter manufacturer name and P/N of luminaire under consideration in the "search by keyword" text window.
- D) Select "Search" tab to open the "Qualified Products List".
- E) Determine luminaire Lumens per Watt efficacy in "Rated Data" specifications.
- F) Multiply luminaire Lumens per Watt by Emergency Output of the emergency driver under consideration (refer to the Electrical Information section). This figure is the Lumens available from the luminaire during emergency operation.

3) Determine Suitability of Means of Egress Lighting Levels

- A) Using industry standard lighting design software, along with IES files for the luminaire under consideration, verify that the as installed available Lumens (as calculated in 2F above) are sufficient to meet Code-compliant path of egress illumination levels.

While the emergency driver series has been found compliant with the requirements of UL Standard 924, it is ultimately the responsibility of the Designer/Specifier to ensure the as-installed system delivers code-compliant path of egress illumination in accordance with Federal, State or local municipal requirements.

BLEMSLP-CP

Constant-Power Emergency LED Driver with separate battery



STANDARD



ILLUMINATION

- Works with or without an AC driver to convert new or existing LED fixtures into unobtrusive emergency lighting.
- Provides constant power output to the load during emergency mode operation.
- Designed to operate NORMALLY-ON, NORMALLY-OFF or SWITCHED LOAD fixtures.

ELECTRICAL

- Universal 120-277V, 50/60 Hz input.
- Charge/Power "ON" LED indicator light and push-to-test switch for mandated code compliance testing.
- Long-life, maintenance free, rechargeable Lithium iron phosphate battery.
- Output short/overcurrent protection: Electronic limiting, with normal operation resuming upon removal of fault.
- 90 Minute minimum emergency operating time over full temperature range.
- Output classification: Class 2 Compliant.
- Surge protection: Per C62.41 (TVS).
- Input overcurrent protection: Fusible link.
- 24 Hour maximum battery recharge time.

HOUSING

- LED Illuminated test switch.
- Low profile galvanized steel construction.
- Compact split-version design fits most LED fixtures.

MOUNTING

- Suitable for installation inside LED fixtures.

WARRANTY/LISTING

- UL Classified for factory or field installation.
- Suitable for wet locations (-10°C - 55°C).
- 5 year warranty on all electronics and housing.
- Meets UL924, NFPA 101 Life Safety Code, NEC, OSHA, Local and State codes.
- Certified to CEC under Title 20 regulations.

DIMENSIONS

BLEMSLP-CP-5 & BLEMSLP-CP-10 Driver

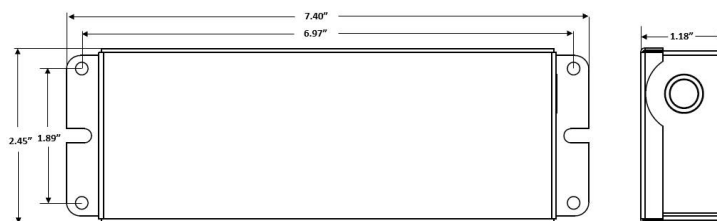

BLEMSLP-CP-5 Battery bracket

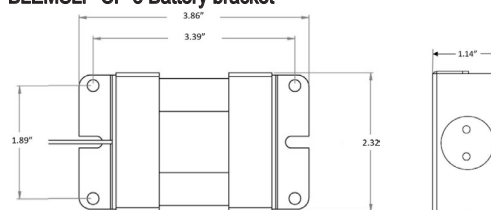

BLEMSLP-CP-10 Battery bracket

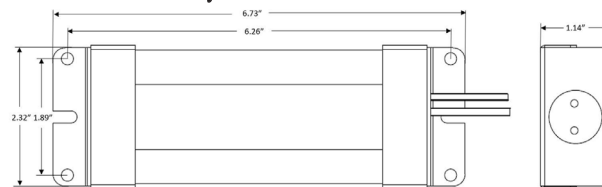

ORDERING INFORMATION

MODEL	OUTPUT POWER	
	BLEMSLP-CP	5
	10	10.7 Watts

Sample Part Number: **BLEMSLP-CP-10**

BLEMSLP-CP

Constant-Power Emergency LED Driver with separate battery

ELECTRICAL INFORMATION

MODEL	INPUT CURRENT (A)	INPUT POWER (W)	OUTPUT VOLTAGE (V)	OUTPUT POWER (W)	OUTPUT CURRENT (mA)
BLEMSLP-CP-5	0.061	3.9	20-50	5.0	250-100
BLEMSLP-CP-10	0.087	5.7	20-50	10.7	535-214

WIRING DIAGRAM

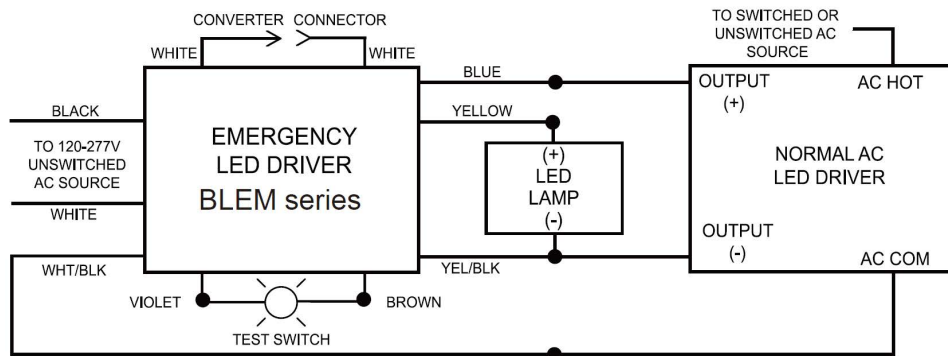

BLEM-CP Series System Coordination Guidelines

These guidelines were developed to allow the lighting system Designer/Specifier to predict the operating performance levels of LED luminaires when powered by an electrically compatible BLEMSLP-CP series model. It is ultimately the responsibility of the Designer/Specifier to ensure that the as installed system delivers the code-compliant path of egress illumination.

1) Determine Electrical Compatibility

- Verify that the Luminaire LED Driver, where applicable, is Class 2 compliant.
- Verify that the Luminaire LED Lamp(s) have an operating voltage between 20Vdc and 50Vdc range.
- Verify that the Luminaire LED Lamp(s) have a power rating equal to, or greater than, the emergency power rating of the BLEMSLP-CP model under consideration (refer to the Electrical Information section).

2) Calculate Lumen Output During Emergency Operation

- Access luminaire data by logging onto Design Lites Consortium (www.designlights.org).
- Select "Search the DLC Qualified Product List" on the DLC homepage.
- Enter manufacturer name and P/N of luminaire under consideration in the "search by keyword" text window.
- Select "Search" tab to open the "Qualified Products List".
- Determine luminaire Lumens per Watt efficacy in "Rated Data" specifications.
- Multiply luminaire Lumens per Watt by Emergency Output of the BLEMSLP-CP model under consideration (refer to the Electrical Information section). This figure is the Lumens available from the luminaire during emergency operation.

3) Determine Suitability of Means of Egress Lighting Levels

- Using industry standard lighting design software, along with IES files for the luminaire under consideration, verify that the as installed available Lumens (as calculated in 2F above) are sufficient to meet Code-compliant path of egress illumination levels.

While the BLEMSLP-CP series has been found compliant with the requirements of UL Standard 924, it is ultimately the responsibility of the Designer/Specifier to assure the as-installed system delivers code-compliant path of egress illumination in accordance with Federal, State or local municipal requirements.

MPS Series Inverters

Emergency Micro Power Systems



True Sinusoidal Output Power



Surface Mount Models

DESCRIPTION

- MPS Series inverter systems are designed to provide sinusoidal AC emergency power to connected incandescent, uorescent or LED fixtures of between 20 and 55 watts.
- Surface, recessed or ceiling T-Grid mount models are designed for easy installation either on or near controlled fixtures. MPS models support Normally-ON, Normally-OFF, switched operation or any combination thereof (see wiring diagram).

ELECTRICAL SPECIFICATIONS

Input

- Input Voltages: 120 or 277VAC $\pm 10\%$
- Input Frequencies: 60Hz $\pm 2\%$
- Input Protection: Provided by Service Panel, Rated 20A max.

Output

- Output Voltages: 120 or 277VAC (60Hz)
- Efficiency Rating: 98% at full rated load (line)
- Waveform: Sinusoidal (digitally controlled, PWM design)
- Static Voltage: $\pm 5\%$ during battery discharge. 0-100% linear load.
- Output Frequencies: 60Hz. ± 0.3 Hz during emergency cycle
- Output Distortion: Less than 3% THD (linear load)
- Transfer Time: Less than 1.0 second
- Load Power Factor Range: 0.44 Lead to 0.44 Lag
- Minimum Loading: 0% of rated system capacity
- Output Protection: Inverter fuse

HOUSING

- Heavy duty steel cabinet is finished in white baked-on powder paint providing scratch and corrosion resistance.
- Optional paint color (-SP) finishes available, consult factory.

Optional Ceiling T-grid Mount Housing

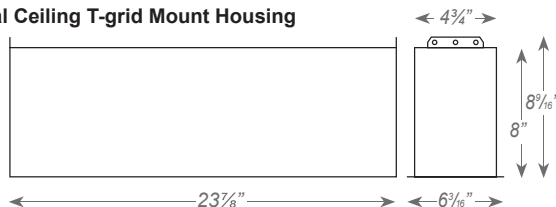

MOUNTING

- Surface Mount:** Surface mount models are designed for mounting to walls by means of keyhole slots provided in the back of the unit housing.
- Recess Mount:** Recess models provide recess mounting holes on both sides of the enclosure.
- T-Grid Mount:** Housing design allows simple drop-in installation between t-grid runs. Safety wires (supplied by others) are required for attachment to building structure.

WARRANTY / LISTING

- Unit:** (excluding lamps) Full coverage against defects in materials and workmanship for 3 years from date of shipment.
- Battery:** 3 years Lead-Acid, 5 yrs NiCd full warranty plus an additional 7 years of pro-rata coverage.
- All models are UL924 Listed and meet NFPA 101 Life Safety Code, NEC, OSHA, Local and State Codes. Optional T-Grid models are plenum rated, to UL2043 and meets city of Chicago CCEA Requirements.
- UL Listed for damp locations (0° - 50°C for NiCad models and 20° - 30°C for lead-calcium models).
- Optional -CEC models are Certified to CEC Under Title 20 regulations
- FCC Part 15 Class B Compliant.

DIMENSIONS

Standard Surface Mount Housings

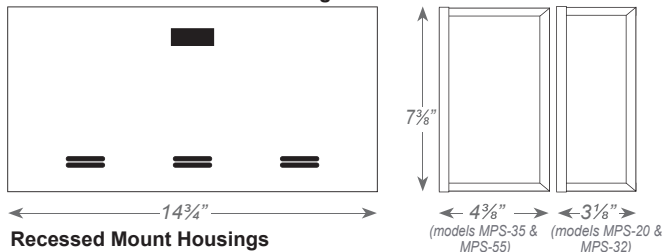

Recessed Mount Housings

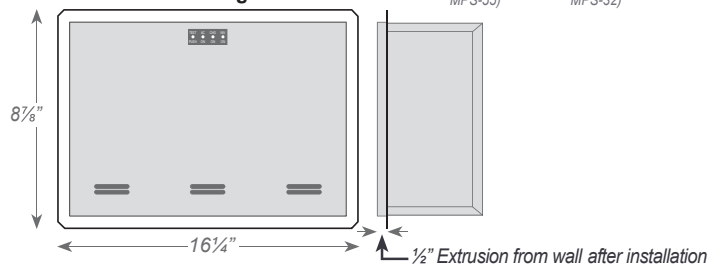

MPS Series Inverters

Emergency Micro Power Systems

The MPS Series is designed to provide 20W to 55W of emergency power to incandescent, fluorescent, and/or LED fixtures. The MPS unit provides clean, sinusoidal AC output power allowing it to be remotely mounted up to 1,000 feet away from the controlled fixture(s).



Unlike a ballast fluorescent emergency pack, the MPS provides power to the input side of the fixture, (including the ballast) eliminating any chance of incompatibility. MPS Series models are available for surface, recessed or ceiling T-Grid mounting if required. All MPS systems will provide emergency power output for a minimum of 90-minutes.

FEATURES

- For powering incandescent, fluorescent, and LED fixtures *
- True sinusoidal AC pulse width modulated (PWM) design provides clean 60Hz. emergency output
- Universal 120/277VAC, 60Hz. input/output
- Unit capacities of 20W to 55W
- "Soft Start" design reduces fixture inrush current
- Surface, recessed or T-Grid mount models
- Lumen output from fixture is 100% of nominal
- Unique design eliminates compatibility problems with LED drivers as well as fluorescent ballasts
- Normally-ON and/or Normally-OFF load output
- Provisions for local switching capability - Always-ON during emergency conditions regardless of local switch position
- Temperature compensated, dual-mode charger includes low voltage disconnect feature to provide protection against battery deep discharge
- Maintenance-free Lead-Calcium and premium grade Nickel-Cadmium battery models offered
- Control panel with momentary test switch, AC-ON, Charge-ON and Inverter-ON LED indicators
- Battery circuit fuse protected
- Reverse battery and AC lockout protection

* Consult factory for compatibility for other lamp types

WIRING

Connection to an unswitched AC circuit is required by the NEC. Wiring access is provided for by conduit knockouts in the unit housing. MPS Series models also provide knockouts in the back of the housing for rear wiring from standard electrical boxes when surface mounting.

LOAD COMPATIBILITY

MPS model's clean, sinusoidal AC output will operate incandescent lamps as well as all common fluorescent and LED lamp types. Consult factory for compatibility with all other lamp types.

Lighting loads are driven at 100% output for the entire emergency power cycle. This outstanding feature translates into greater occupant egress vision and safety.

SYSTEM OPTIONS ⁽¹⁾⁽²⁾

ADD SUFFIX	DESCRIPTION
-S	Surface Mount Housing
-R	Recess Mount Housing
-T	Plenum Rated Ceiling T-Grid Mount Housing
-SP	Special Housing Color (specify)
-RTS	Remote Test Switch Panel ⁽³⁾
-SDT	Self-Testing / Self-Diagnostics ⁽³⁾
-CEC	Title 20 Compliant

⁽¹⁾ Other options available. Consult factory.

⁽²⁾ Some options may impact product UL listing. Consult factory.

⁽³⁾ For more information, separate specification sheets are available on the -RTS and -SDT options. Consult factory.

GENERAL SPECIFICATIONS

MODEL NUMBER	HOUSING SIZE	INPUT / OUTPUT VOLTS	90 min. CAPACITY (Watts/VA)	SYSTEM WEIGHT*		BATTERY TYPE	TEMP. RANGE (°C)	POWER CONSUM. (Max.)	BATTERY VOLTAGE (VDC)	DC INPUT CURRENT (A _{dc})	INPUT CURRENT		THERMAL OUTPUT in BTUs	
				Lbs.	Kg.						120VAC (max)	277VAC (max)	STANDBY	EMERGENCY
MPS-32	Small	120/277	32/32	14.0	6.4	Lead-Calc	20-30°	9W	12	3.4	0.34A	0.15A	7	32
MPS-55	Large	120/277	55/55	18.0	8.2	Lead-Calc	20-30°	9W	12	5.7	0.54A	0.23A	7	47
MPS-20	Small	120/277	20/20	11.0	5.0	NiCad	0-50°	9W	12	2.1	0.25A	0.11A	31	22
MPS-35	Large	120/277	35/35	12.0	5.4	NiCad	0-50°	9W	12	3.8	0.37A	0.16A	31	35

* System weights shown include installed batteries

MPS Series Inverters

Emergency Micro Power Systems

BATTERIES AND CHARGER

Battery

Battery: Sealed Lead Calcium (10 year life) or Sealed Nickel-Cadmium (15 year life)

Battery Voltage: 12VDC for all MPS models

Runtime: 90-minutes standard. Other runtimes available, consult factory.

Battery Protection: Low Voltage Battery Disconnect protects the battery from being severely damaged by deep discharge during prolonged power failures.

DC Overload and Short Circuit Protection provided by a DC input fuse.

Charger

Charger Type: Fully automatic, temperature compensated, dual-mode charger

Power Consumption: 9W max. (All models)

Recharge Duty Cycle: Meets UL924 requirements

Controls: Momentary test switch, AC-ON, Charge-ON and Inverter-ON LED indicator lights

Safety Circuitry: AC Lockout prevents battery discharge prior to initial unit power-up.

Brownout Protection automatically switches the unit to emergency mode when utility voltage is significantly reduced.

Environmental

Altitude: < 10,000 feet (3,000m) above sea level without derating.

Operating Temperature Range:

Lead-Calcium Models: 20°C to 30°C

Nickel-Cadmium Models: 0°C to 50°C

NOTE: Optimum system performance between 20°C and 30°C; temperatures outside of this range will affect battery performance and life.

Relative Humidity: 95% non-condensing

OPERATION

Upon failure of the normal utility power the MPS unit is automatically turned on by a solid-state switching circuit and provides a minimum of 90-minutes of emergency power to the connected load. Lumen output will be maintained at 100% of the lamp's rating throughout the entire duration.

A solid-state low voltage disconnect circuit is used to protect the battery from being severely damaged by a deep discharge. When normal utility power is restored, the unit switches the load back to normal utility operation and the fully automatic, temperature compensated, dual mode charger begins to restore the battery; bringing it to full charge within UL924 specified parameters. A brownout sensing circuit insures proper operation during "low line" conditions.

SYSTEM STATUS MONITORING PANEL

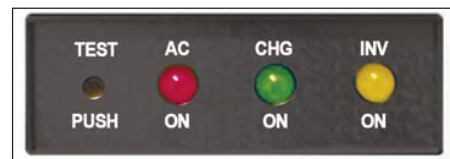

All MPS systems provide a monitoring panel on the front of the unit to show operating status at all times. The panel provides a test switch for user initiated system tests and a 3-LED array that provides an intuitive visual indication of unit readiness.

IMPROVED AESTHETICS

The MPS system's sinusoidal AC output design eliminates voltage drop and proximity concerns. This allows added flexibility in installation location as MPS units can be installed hundreds of feet from the units they power. This means MPS units to be located conveniently out of sight in closets or utility rooms without interrupting architectural aesthetics.

In lighting applications, no special or additional emergency fixtures are necessary. Simply designate and connect existing lighting fixtures, either interior or exterior, to the MPS unit for emergency operation eliminating the need for exposed, stand-alone emergency luminaires.

MPS SYSTEM ADVANTAGES

Compared to traditional discrete emergency lighting units, the MPS Series provides emergency illumination from a single power source resulting in lower maintenance overhead and routine testing expenses.

MPS units lower installation costs by powering existing lighting fixtures during emergencies. And because connected fixtures are driven at full brilliancy, they provide far superior egress lighting and deliver improved occupant safety.

MPS Series Inverters

Emergency Micro Power Systems

SUGGESTED SPECIFICATIONS

An inverter system with sinusoidal output shall be supplied capable of powering any combination of lighting fixtures, including incandescent, fluorescent, induction and/or LED light sources without compatibility problems.

The system shall transfer in less than 1.0 second to reliably back up lighting fixtures without loss of illumination and operate any and all connected lighting fixtures at full lumen output during the complete 90-minute discharge cycle.

The input voltage shall be the same as the output voltage and shall be single phase 120/277 volts, 60Hz. Output capacity will be (20 Watts/32 Watts) / (35 Watts/55 Watts) for a minimum duration of 90-minutes.

The design shall be a standby, off-line inverter with on-line efficiency of 98%; on-line double conversion UPS systems shall not be considered acceptable alternatives. MPS system output shall be a PWM generated sine wave with less than 3% total harmonic distortion with "Soft-Start" design reducing fixture inrush current. The system shall also provide short circuit and overload protection as standard.

An intuitive three LED display shall provide system operational information at a glance and alert user to any malfunction in system performance. Authorized maintenance personnel shall have access to the system's controls while being protected from any live exposed connections.

Protective devices shall include DC input fuse, AC input overcurrent protection for live circuits to be provided by service panel rated 20A maximum. AC lockout, reverse battery connection, low voltage battery disconnect (LVD), short circuit and overload protection shall be provided standard on all models. The entire MPS system, including batteries, shall be provided in compact cabinetry which shall have provisions for surface, recessed, T-Grid mounting.

System shall be capable of providing, remote test switch, and self-test/self-diagnostics, were necessary.

System shall utilize a sealed lead calcium battery with a 10 year design life or a sealed Nickel-Cadmium battery with a 15 year design life. The charger shall be temperature compensated, dual mode type, and recharge the batteries as per UL924 guidelines. Entire system shall be tested, approved, and labeled to UL924 Emergency Lighting and Power Systems standards. T-Grid models will be plenum rated.

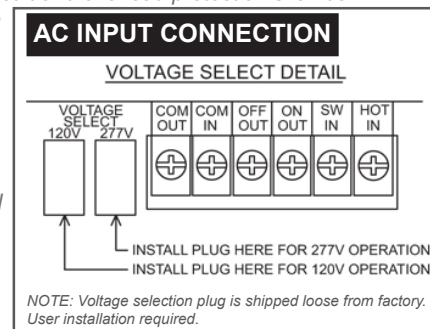

WIRING DIAGRAMS

NORMALLY ON LOADS

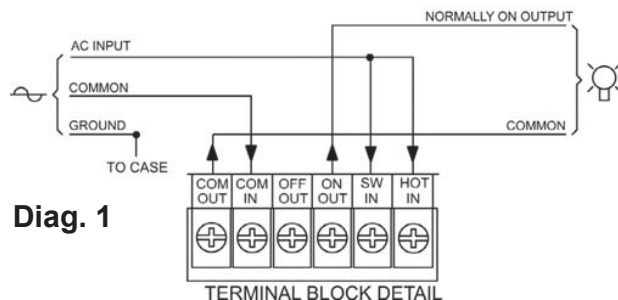

Diag. 1

NORMALLY OFF LOADS

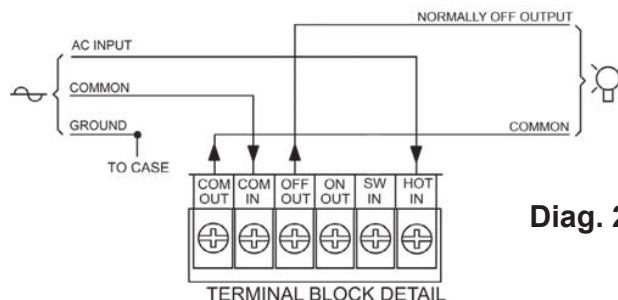

Diag. 2

NORMALLY ON & OFF LOADS

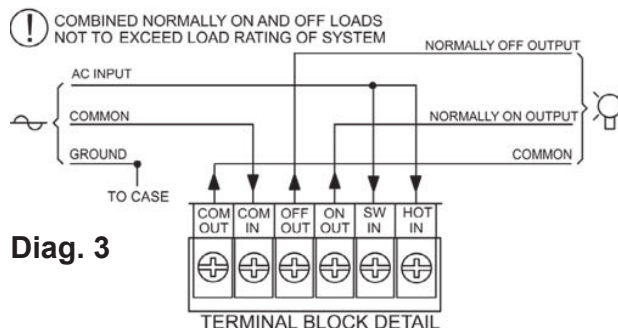

Diag. 3

SWITCHED LOADS

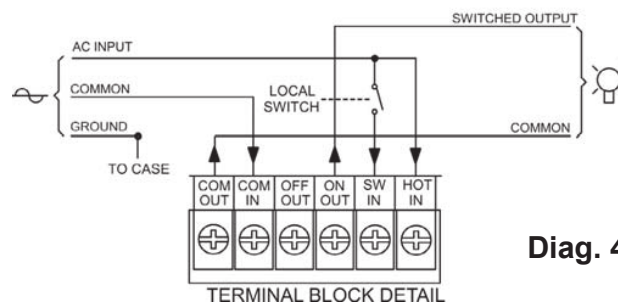

Diag. 4

⚡ INPUT SUPPLY FROM UNSWITCHED UTILITY RATED 20 AMPS MAXIMUM.
 ⚡ OUTPUT(S) TO LIGHTING LOADS

SPS Series Inverters

Emergency Power Systems

STANDARD



OPTIONAL



DESCRIPTION

- Mini-electrical inverter systems for powering up to 220W/250VA of incandescent, fluorescent, induction or LED lighting loads. Pulse width modulated (PWM) output design provides clean, 60 Hz. sinusoidal emergency power to loads.
- Models are available for surface, recessed or T-Grid mounting as required.

ELECTRICAL SPECIFICATIONS

Input

- Input Voltages: 120 or 277VAC $\pm 10\%$
- Input Frequencies: 60Hz $\pm 2\%$
- Input Protection: AC Line Fuses

Output

- Output Voltages: (60Hz) 120 or 277VAC
- Efficiency Rating: 98% at full rated load (line)
- Waveform: Sinusoidal (digitally controlled)
- Static Voltage: $\pm 5\%$ during battery discharge. 0-100% linear load.
- Output Frequencies: 60Hz. ± 0.3 Hz during emergency cycle
- Output Distortion: Less than 3% THD (linear load)
- Transfer Time: Less than 1.0 second
- Load Power Factor Range: 0.44 Lead to 0.44 Lag
- Minimum Loading: 0% of rated system capacity
- Output Protection: Line and inverter fuses

HOUSING

- Heavy duty steel cabinet is finished in white baked-on powder paint providing scratch and corrosion resistance.
- Optional special color paint (-SP) finishes are available, consult factory.

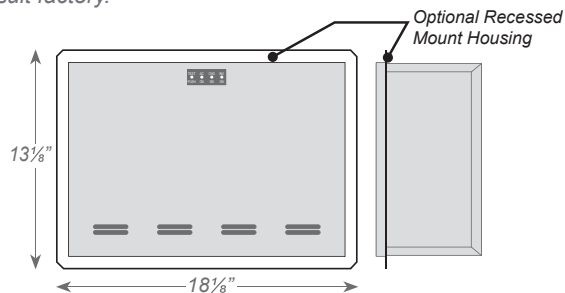

MOUNTING

- **Surface Mount (Standard Models):** Surface mount models are designed for mounting to walls by means of keyhole slots provided in the back of the unit housing.
- **Recess Mount (SPS-55/125, SPS-110/125 Only):** Recess models provide recess mounting holes on both sides of the enclosure.
- **T-Grid Mount (SPS-55/125, SPS-110/125 Only):** Housing design allows simple drop-in installation between T-grid runs. Safety wires (supplied by others) are required for attachment to building structure.

WARRANTY / LISTING

- **Unit:** (excluding lamps) Full coverage against defects in materials and workmanship for 3 years from date of shipment.
- **Battery:** 3 years full warranty plus an additional 7 years of pro-rata coverage.
- All models are UL924 Listed and meet NFPA 101 Life Safety Code, NEC, OSHA, Local and State Codes. Optional T-Grid models are plenum rated, to UL2043 and meets city of Chicago CCEA Requirements.
- UL Listed for damp locations (20° - 30°C).
- Optional -CEC models are Certified to CEC Under Title 20 regulations
- FCC Part 15 Class B Compliant.

DIMENSIONS

Standard Surface Mount Housings

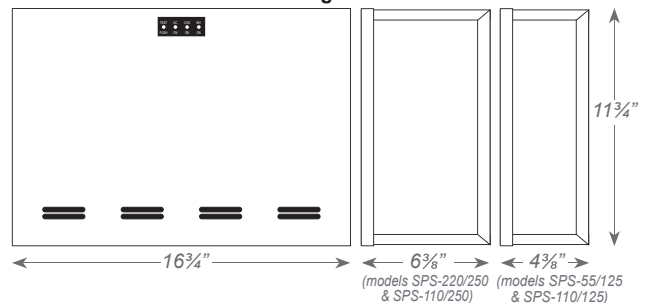

Optional Ceiling T-grid Mount Housing

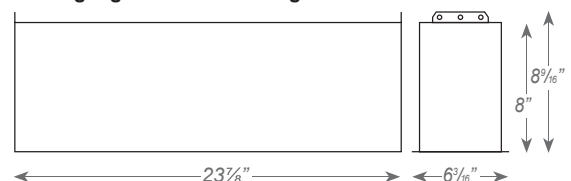

SPS Series Inverters

Emergency Power Systems



The SPS Series is designed to provide up to 220W/250VA of emergency power to incandescent, fluorescent, induction and/or LED fixtures. The SPS unit provides clean, sinusoidal AC output power allowing it to be remotely mounted up to 1,000 feet away from the controlled fixture(s).

Unlike a ballast fluorescent emergency pack, the SPS provides power to the input side of the fixture, (including the ballast) eliminating any chance of incompatibility. The SPS Series is designed primarily for surface mounting, however, the SPS-55/125 and SPS-110/125 models provide optional housings for recessed or ceiling T-Grid mounting if required. All SPS systems will provide emergency power output for a minimum of 90-minutes.

FEATURES

- For powering incandescent, fluorescent, induction and LED fixtures *
- Sinusoidal output eliminates compatibility problems
- Universal 120/277VAC, 60Hz. input/output
- Unit capacities up to 220W/250VA
- “Soft Start” design reduces fixture inrush current
- Unit may be installed up to 1,000 feet from controlled fixture(s)
- Surface, recessed or T-Grid mount models
- Lumen output from fixture is 100% of nominal
- Unique design eliminates compatibility problems with LED drivers as well as fluorescent and induction ballasts
- Compatible with dimming ballasts
- Normally-ON and/or Normally-OFF load output
- Provisions for local switching capability - Always on during emergency conditions regardless of local switch position
- Emergency fixtures can be ON, OFF or SWITCHED
- Solid-state, line latched low voltage disconnect provides protection against battery deep discharge
- Long life, maintenance-free lead-calcium battery
- Momentary test switch
- AC-ON, Charge-ON and Inverter-ON LED indicators

* Consult factory for compatibility for other lamp types

WIRING

Connection to an unswitched AC circuit is required by the NEC. Wiring access is provided for by conduit knockouts in the unit housing. SPS-55/125 and SPS-110/125 models also provide knockouts in the back of the housing for rear wiring from standard electrical boxes when surface mounting.

LOAD COMPATIBILITY

SPS model's clean, sinusoidal AC output will operate incandescent lamps as well as all common fluorescent, induction and LED lamp types. Consult factory for compatibility with all other lamp types.

Lighting loads are driven at 100% output for the entire emergency power cycle. This outstanding feature translates into greater occupant egress vision and safety.

SYSTEM OPTIONS ^{(1) (2)}

ADD SUFFIX	DESCRIPTION
-S	Surface Mount Housing
-R	Recess Mount Housing ⁽³⁾
-T	Plenum Rated Ceiling T-Grid Mount Housing ⁽³⁾
-SP	Special Housing Color (specify)
-4C	4 Output Circuit Switching ⁽⁴⁾
-RTS	Remote Test Switch Panel ⁽⁴⁾
-AO	Adjustable Output/Dimmer Bypass ⁽⁴⁾
-SDT	Self-Testing / Self-Diagnostics ⁽⁴⁾
-CEC	Title 20 Compliant

⁽¹⁾ Other options available. Consult factory.

⁽²⁾ Some options may impact product UL listing. Consult factory.

⁽³⁾ Available with SPS-55/125 and SPS-110/125 models only.

⁽⁴⁾ For more information, separate specification sheets are available on the -4C, -RTS, -SDT and -AO options. Consult factory.

GENERAL SPECIFICATIONS

MODEL NUMBER	INPUT / OUTPUT VOLTS	CAPACITY for 1½ Hrs.		SYSTEM WEIGHT*		ON-LINE SYSTEM EFFICIENCY (full load)	NUMBER of BATTERIES	BATTERY VOLTAGE (VDC)	BATTERY CURRENT (amps)	AC INPUT CURRENT		THERMAL OUTPUT in BTUs	
		WATTS	VA	Lbs.	Kg.					120VAC (max)	277VAC (max)	ON-LINE	EMERGENCY
SPS-55/125	120/277	55	125	30.0	14	98%	2	24	3.4	1.2	0.52	9	90
SPS-110/125	120/277	110	125	42.0	17	98%	2	24	5.7	1.2	0.52	9	95
SPS-110/250	120/277	110	250	45.2	21	98%	4	48	3.3	2.4	1.10	18	163
SPS-220/250	120/277	220	250	60.0	27	98%	4	48	5.6	2.4	1.10	18	167

* System weights shown include installed batteries

SPS Series Inverters

Emergency Power Systems

BATTERIES AND CHARGER

Battery

Battery: Sealed Lead Calcium (10 year life)

Battery Voltage: 24VDC for SPS-55/125, SPS-110/125 models and 48VDC for SPS110/250, SPS220/250 models

Runtime: 90-minutes standard - based on battery performance at (25°C). Other runtimes available, consult factory.

Battery Protection: Low Voltage Battery Disconnect protects the battery from being severely damaged by deep discharge during prolonged power failures.

DC Overload and Short Circuit Protection provided by a DC input breaker and fuse.

Charger

Charger Type: Fully automatic, temperature compensated, dual-mode charger

Power Consumption (Charger Only):

15W maximum (2.5W in standby) for SPS-55/125, and SPS-110/125 models

30W maximum (5W in standby) for SPS110/250, and SPS220/250 models

Recharge Duty Cycle: Meets UL924 requirements

Battery Circuit Breaker: Also used as battery isolator

Controls: Momentary test switch, AC-ON,

Charge-ON and Inverter-ON LED indicator lights

Safety Circuitry: AC Lockout prevents battery discharge prior to initial unit power-up.

Brownout Protection automatically switches the unit to emergency mode when utility voltage is significantly reduced.

Environmental

Altitude: < 10,000 feet (3,000m) above sea level without derating.

Operating Temperature Range: 20°C to 30°C

NOTE: Optimum system performance between 20°C and 30°C; temperatures outside of this range will affect battery performance and life.

Relative Humidity: 95% non-condensing

OPERATION

Upon failure of the normal utility power the SPS unit is automatically turned on by a solid-state switching circuit and provides a minimum of 90-minutes of emergency power to the connected load. Lumen output will be maintained at 100% of the lamp's rating throughout the entire duration.

A solid-state low voltage disconnect circuit is used to protect the battery from being severely damaged by a deep discharge. When normal utility power is restored, the unit switches the load back to normal utility operation and the fully automatic, temperature compensated, dual mode charger begins to restore the battery; bringing it to full charge within UL924 specified parameters. A brownout sensing circuit insures proper operation during "low line" conditions.

SYSTEM STATUS MONITORING PANEL

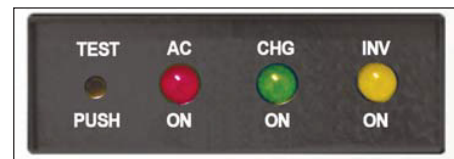

All SPS Systems provide a monitoring panel on the front of the unit to show operating status at all times. The panel provides a test switch for user initiated system tests and a 3-LED array that provides an intuitive visual indication of unit readiness.

IMPROVED AESTHETICS

The SPS System's sinusoidal AC output design eliminates voltage drop and proximity concerns. This allows added flexibility in installation location as SPS units can be installed hundreds of feet from the units they power. This means SPS units to be located conveniently out of sight in closets or utility rooms without interrupting architectural aesthetics.

In lighting applications, no special or additional emergency fixtures are necessary. Simply designate and connect existing lighting fixtures, either interior or exterior, to the SPS unit for emergency operation eliminating the need for exposed, stand-alone emergency luminaires.

SPS SYSTEM ADVANTAGES

Compared to traditional discrete emergency lighting units, the SPS Series provides emergency illumination from a single power source resulting in lower maintenance overhead and routine testing expenses.

SPS units lower installation costs by powering existing lighting fixtures during emergencies. And because connected fixtures are driven at full brilliancy, they provide far superior egress lighting and deliver improved occupant safety.

SPS Series Inverters

Emergency Power Systems

SUGGESTED SPECIFICATIONS

An inverter system with sinusoidal output shall be supplied capable of powering any combination of lighting fixtures, including incandescent, fluorescent, induction and/or LED light sources without compatibility problems.

The system shall transfer in less than 1.0 second to reliably back up lighting fixtures without loss of illumination and operate any and all connected lighting fixtures at full lumen output during the complete 90-minute discharge cycle.

The input voltage shall be the same as the output voltage and shall be single phase 120/277 volts, 60 Hz. Output capacity will be (55W/125VA) / (110 Watts/125VA) / (110 Watts/250VA) / (220 Watts/250VA) for a minimum duration of 90-minutes.

The design shall be a standby, off-line inverter with on-line efficiency of 98%; on-line double conversion UPS systems shall not be considered acceptable alternatives. SPS System output shall be a PWM generated sine wave with less than 3% total harmonic distortion with "Soft-Start" design reducing fixture inrush current. The system shall also provide short circuit and overload protection as standard.

An intuitive three LED display shall provide system operational information at a glance and alert user to any malfunction in system performance. Authorized maintenance personnel shall have access to the system's controls while being protected from any live exposed connections.

Protective devices shall include AC Line fuses, DC input breaker and a DC input fuse. The entire SPS system, including batteries, shall be incorporated into compact cabinetry which shall have provisions for (surface, recessed or T-Grid) mounting.

System shall be capable of providing up to 4 switch bypass circuits, adjustable output or 0 to 10 volt dimmer bypass, remote test switch, and self-test/self-diagnostics, were necessary

System shall utilize a sealed lead calcium battery with a 10 year design life. The charger shall be temperature compensated, dual mode type, and recharge the batteries as per UL924 guidelines. Entire system shall be tested, approved, and labeled to UL924 Emergency Lighting and Power Systems standards. T-Grid models will be plenum rated.

WIRING DIAGRAMS

120VAC Connections

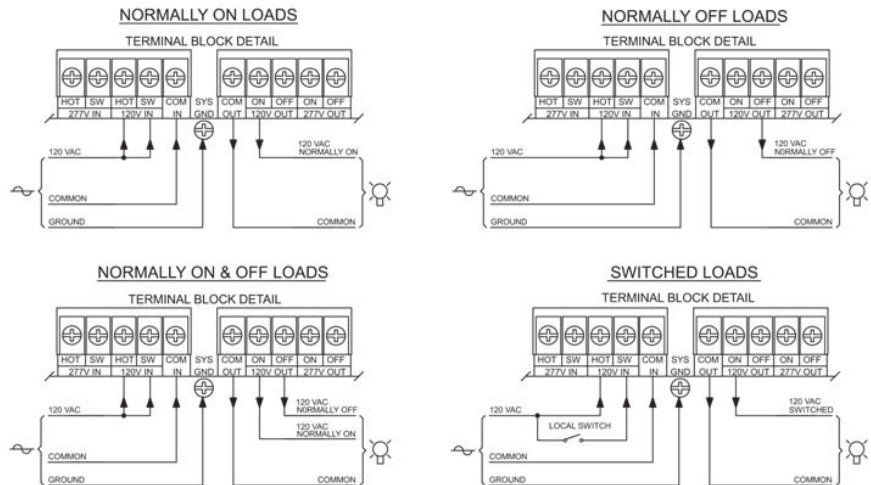

277VAC Connections

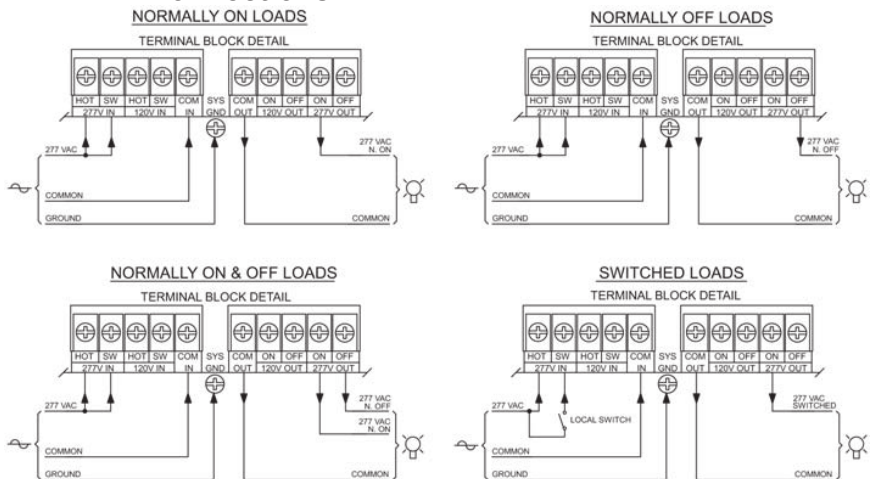

LPS Series Inverters

Emergency Power Systems

STANDARD



OPTIONAL



DESCRIPTION

- Midsize-electrical inverter systems for powering 375 up to 600 watts of incandescent, fluorescent, induction or LED lighting loads. Pulse width modulated (PWM) output design provides clean, 60 Hz. sinusoidal emergency power to loads.
- All models are designed for fast, easy wall mounting.

ELECTRICAL SPECIFICATIONS

Input

- Input Voltages: Universal 120 or 277VAC, 60Hz (User selectable with (2) wire jumpers provided)
- Input Frequencies: 60Hz \pm 2%
- Input Surge Protection: Meets UL924
- Input Protection: Provided by Service Panel rated at 20 amps maximum

Output

- Output Voltages: (60Hz) 120 or 277VAC
- Efficiency Rating: 98% at full rated load (line)
- Waveform: Sinusoidal (digitally controlled)
- Static Voltage: \pm 5% during battery discharge. 0-100% linear load.
- Output Frequencies: 60Hz. \pm 0.3Hz during emergency cycle
- Output Distortion: Less than 3% THD (linear load)
- Transfer Time: Less than 1.0 second
- Load Power Factor Range: 0.44 Lead to 0.44 Lag
- Minimum Loading: 0% of rated system capacity
- Output Protection: Circuit breaker

HOUSING

- Heavy duty steel cabinet is finished in white baked-on powder paint providing scratch and corrosion resistance.
- Optional special color paint (-SP) finishes are available, consult factory.

MOUNTING

- Surface Mount: Surface mount models are designed for mounting to walls by means of keyhole slots provided in the back of the unit housing.

True
Sinusoidal
Output Power



WARRANTY / LISTING

- Unit: (excluding lamps) Full coverage against defects in materials and workmanship for 3 years from date of shipment.
- Battery: 3 years full warranty plus an additional 7 years of pro-rata coverage.
- All models are UL924 Listed and meet NFPA 101 Life Safety Code, NEC, OSHA, Local and State Codes.
- UL Listed for damp locations (20° - 30°C).
- Certified to CEC under Title 20 Regulations.

DIMENSIONS

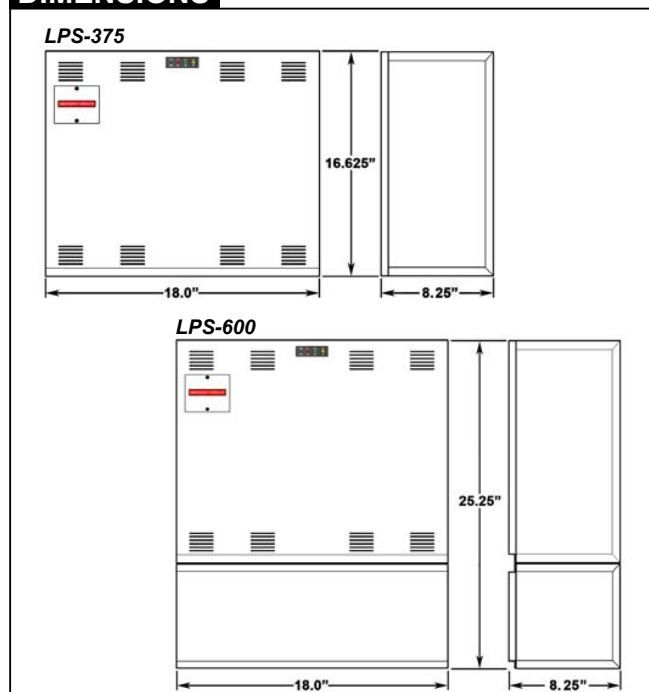

LPS Series Inverters

Emergency Power Systems

The LPS Series is designed to provide 375 to 600 watts of emergency power to incandescent, fluorescent, induction and/or LED fixtures. The LPS unit provides clean, sinusoidal AC output power allowing it to be remotely mounted up to 1,000 feet away from the controlled fixture(s).

Unlike a ballast fluorescent emergency pack, the LPS provides power to the input side of the fixture, (including the ballast) eliminating any chance of incompatibility. The LPS Series is designed for surface mounting. All LPS systems will provide emergency power output for a minimum of 90-minutes.



FEATURES

- For powering incandescent, fluorescent, induction and LED fixtures *
- Sinusoidal output eliminates compatibility problems
- Universal 120/277VAC, 60Hz. input/output
- Unit capacities up to 600 watts
- “Soft Start” design reduces fixture inrush current
- Unit may be installed up to 1,000 feet from controlled fixture(s)
- Lumen output from fixture is 100% of nominal
- Unique design eliminates compatibility problems with LED drivers as well as fluorescent and induction ballasts
- Compatible with dimming ballasts
- Normally-ON and/or Normally-OFF load output
- Provisions for local switching capability - Always on during emergency conditions regardless of local switch position
- Emergency fixtures can be ON, OFF or SWITCHED
- Solid-state, line latched low voltage disconnect provides protection against battery deep discharge
- Long life, maintenance-free lead-calcium battery
- Momentary test switch
- AC-ON, Charge-ON and Inverter-ON LED indicators

* Consult factory for compatibility for other lamp types

WIRING

Connection to an unswitched AC circuit is required by the NEC. Wiring access is provided for by conduit knockouts in the unit housing.

LOAD COMPATIBILITY

LPS model’s clean, sinusoidal AC output will operate incandescent lamps as well as all common fluorescent, induction and LED lamp types. Consult factory for compatibility with all other lamp types.

Lighting loads are driven at 100% output for the entire emergency power cycle. This outstanding feature translates into greater occupant egress vision and safety.

SYSTEM OPTIONS (1)(2)

ADD SUFFIX	DESCRIPTION
-OCB1	One Output Breaker
-OCB2	Two Output Breakers
-ICB	Input Breaker
-SP	Special Housing Color (specify)
-4AO	Adjustable Output/Dimmer Bypass (3)
-4C	Four Output Circuit Switching (3)
-SDT	Self-Testing / Self-Diagnostics (3)

(1) Other options available. Consult factory.

(2) Some options may impact product UL listing. Consult factory.

(3) For more information, separate specification sheets are available on the -4AO, -4C and -SDT options. Consult factory.

GENERAL SPECIFICATIONS

MODEL NUMBER	INPUT/OUTPUT VOLTAGE	CAPACITY For 1 1/2 Hrs. (Watts/VA)	SYSTEM WEIGHT		SYSTEM EFFICIENCY (Full Load)	NUMBER OF BATTERIES	BATTERY VOLTAGE (VDC)	BATTERY CURRENT (Amps)	AC INPUT CURRENT (MAX)		THERMAL OUTPUT (BTUs)	
			Lbs.	Kg.					120VAC	277VAC	On-Line	Emergency
LPS-375	120/277VAC	375/375	113	51.3	98%	5	60	7.3	3.43	1.49	11	205
LPS-600	120/277VAC	600/600	172	78.1	98%	8	96	7.1	5.50	2.38	15	275

LPS Series Inverters

Emergency Power Systems

BATTERIES AND CHARGER

Battery

Battery: Sealed Lead Calcium (10 year life)

Battery Voltage: 60VDC for LPS-375 model and 96VDC for LPS-600 model

Runtime: 90 minutes standard - based on battery performance at 77°F (25°C).

Other runtimes available, consult factory.

Battery Protection: Low Voltage Battery Disconnect protects the battery from being severely damaged by deep discharge during prolonged power failures.

Reverse Polarity, DC Overload and Short Circuit Protection provided by a DC input breaker and fuse.

Charger

Charger Type: Fully automatic, temperature compensated, dual-mode charger

Power Consumption (Charger Only):

37W maximum (2.5W in standby) for LPS-375 model
56W maximum (5W in standby) for LPS-600 model

Recharge Duty Cycle: Meets UL924 requirements

Battery Circuit Breaker: Also used as battery isolator

Controls: Momentary test switch, AC-On, Charge-On and Inverter-On LED indicator lights

Safety Circuitry: AC Lockout prevents battery discharge prior to initial unit power-up.

Brownout Protection automatically switches the unit to emergency mode when utility voltage is significantly reduced.

Environmental

High Altitude Operation: Maximum operating temperature drops 1 degree C per 300 meters (2 degrees F per 1000 feet) above sea level.

Operating Temperature Range: 68°F to 86°F (20°C to 30°C)

NOTE: Optimum system performance between 20°C (68°F) and 30°C (86°F); temperatures outside of this range will affect battery performance and life.

Relative Humidity: 95% non-condensing

OPERATION

Upon failure of the normal utility power the LPS unit is automatically turned on by a solid state switching circuit and provides a minimum of 90 minutes of emergency power to the connected load. Lumen output will be maintained at 100% of the lamp's rating throughout the entire duration.

A solid state low voltage disconnect circuit is used to protect the battery from being severely damaged by a deep discharge. When normal utility power is restored, the unit switches the load back to normal utility operation and the fully automatic, temperature compensated, dual mode charger begins to restore the battery; bringing it to full charge within UL 924 specified parameters. A brownout sensing circuit insures proper operation during "low line" conditions.

SYSTEM STATUS MONITORING PANEL

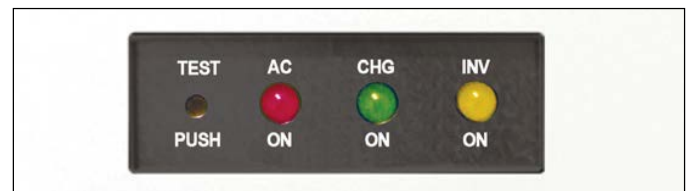

All LPS systems provide a monitoring panel on the front of the unit to show operating status at all times. The panel provides a test switch for user initiated system tests and a 3-LED array that provides an intuitive visual indication of unit readiness.

IMPROVED AESTHETICS

The LPS system's sinusoidal AC output design eliminates voltage drop and proximity concerns. This allows added flexibility in installation location as LPS units can be installed hundreds of feet from the units they power. This means LPS units to be located conveniently out of sight in closets or utility rooms without interrupting architectural aesthetics.

In lighting applications, no special or additional emergency fixtures are necessary. Simply designate and connect existing lighting fixtures, either interior or exterior, to the LPS unit for emergency operation eliminating the need for exposed, stand-alone emergency luminaires.

LPS SYSTEM ADVANTAGES

Compared to traditional discrete emergency lighting units, the LPS Series provides emergency illumination from a single power source resulting in lower maintenance overhead and routine testing expenses. LPS units lower installation costs by powering existing lighting fixtures during emergencies. And because connected fixtures are driven at full brilliancy, they provide far superior egress lighting and deliver improved occupant safety.

LPS Series Inverters

Emergency Power Systems

SUGGESTED SPECIFICATIONS

An inverter system with sinusoidal output shall be supplied capable of powering any combination of lighting fixtures, including incandescent, fluorescent, induction and/or LED light sources without compatibility problems.

The system shall transfer in less than 1.0 second to reliably back up lighting fixtures without loss of illumination and operate any and all connected lighting fixtures at full lumen output during the complete 90-minute discharge cycle.

The input voltage shall be the same as the output voltage and shall be single phase 120/277 volts, 60 Hz. Output capacity will be (375W/375VA) (600W/600VA) for a minimum duration of 90-minutes.

The design shall be a standby, off-line inverter with on-line efficiency of 98%; on-line double conversion UPS systems shall not be considered acceptable alternatives. LPS System output shall be a PWM generated sine wave with less than 3% total harmonic distortion with "Soft Start" design reducing fixture inrush current. The system shall also provide short circuit and overload protection as standard.

An intuitive three LED display shall provide system operational information at a glance and alert user to any malfunction in system performance. Authorized maintenance personnel shall have access to the system's controls while being protected from any live exposed connections.

Protective devices shall include AC Line fuses, DC input breaker and a DC input fuse. The entire LPS system, including batteries, shall be incorporated into compact cabinetry which shall have provisions for surface mounting.

System shall be capable of providing up to 4 switch bypass circuits, adjustable output or 2.5 to 10 volt dimmer bypass and self-test/self-diagnostics, were necessary

System shall utilize a sealed lead calcium battery with a 10 year design life. The charger shall be temperature compensated, dual mode type, and recharge the batteries as per UL924 guidelines. Entire system shall be tested, approved, and labeled to UL924 Emergency Lighting and Power Systems standards.

WIRING DIAGRAMS

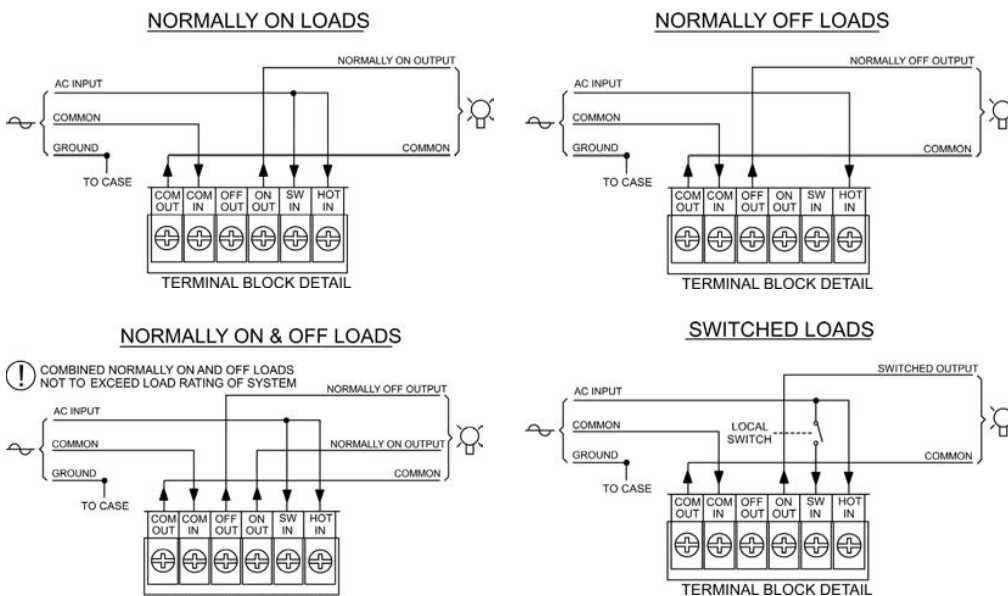

NOTES:

- INPUT SUPPLY FROM UNSWITCHED UTILITY RATED 20 AMPS MAXIMUM.
- OUTPUT(S) TO LIGHTING LOADS

VOLTAGE SELECTION DETAIL

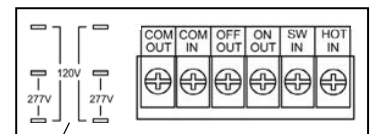

NOTE:

Factory terminated jumper wires are provided with LPS Systems for making user selected input/output voltage connections.

LPS Series Inverters

Higher wattage inverters

Emergency Power Systems

STANDARD



OPTIONAL



True Sinusoidal Output Power

DESCRIPTION

- Midsized-electrical inverter systems for powering up to 750 to 1150 watts of incandescent, fluorescent, induction or LED lighting loads. Pulse width modulated (PWM) output design provides clean, 60 Hz. sinusoidal emergency power to loads
- All models are designed for fast, easy wall mounting

ELECTRICAL SPECIFICATIONS

Input

- Input Voltages: Dual 120 or 277VAC $\pm 10\%$ (User selectable with two jumper wires provided)
- Input Frequencies: 60Hz $\pm 2\%$
- Input Surge Protection: Meets UL924
- Input Protection: Provided by Service Panel rated at 20 amps maximum

Output

- Output Voltages: 120 or 277VAC, 60Hz
- Efficiency Rating: 98% at full rated load (line)
- Waveform: Sinusoidal (digitally controlled)
- Static Voltage: $\pm 5\%$ during battery discharge. 0-100% linear load.
- Output Frequencies: 60Hz. $\pm 0.3\text{Hz}$ during emergency cycle
- Output Distortion: Less than 3% THD (linear load)
- Transfer Time: Less than 1.0 second
- Load Power Factor Range: 0.88 Lead to 0.88 Lag
- Minimum Loading: 0% of rated system capacity
- Output Protection: Circuit breaker and overload shut down protection

MOUNTING

- Surface mount models are designed for mounting to walls by means of keyhole slots provided in the back of the unit housing

HOUSING

- Heavy duty steel cabinet is finished in white baked-on powder paint providing scratch and corrosion resistance
- Optional special color paint (-SP) finishes are available upon request

WARRANTY / LISTING

- Unit: (excluding lamps) Full coverage against defects in materials and workmanship for 3 years from date of shipment
- Battery: 3 years full warranty plus an additional 7 years of pro-rata coverage
- All models are UL924 Listed and meet NFPA 101 Life Safety Code, NEC, OSHA, Local and State Codes.
- UL Listed for damp locations (20° - 30°C)
- Certified to CEC Under Title 20 regulations
- FCC Part 15 Class A Compliant

DIMENSIONS

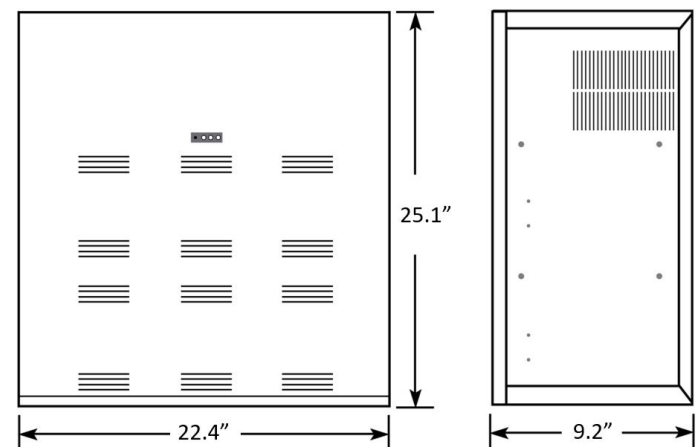

LPS Series Inverters

Higher wattage inverters

Emergency Power Systems

The LPS Series is designed to provide 750 to 1150 watts of emergency power to Incandescent, Fluorescent, Induction and/or LED fixtures. The LPS unit provides clean, sinusoidal AC output power allowing it to be remotely mounted up to 1,000 feet away from the controlled fixture(s).

Unlike a ballast fluorescent emergency pack, the LPS provided power to the input side of the fixture (including the fixture ballast) eliminating any chance of incompatibility. The LPS Series is designed for surface mounting. All LPS systems will provide emergency power output for a minimum of 90 minutes.



FEATURES

- For powering incandescent, fluorescent, induction and LED fixtures *
 - Sinusoidal output eliminates compatibility problems
 - Universal 120/277VAC, 60Hz. input/output
 - Unit capacities up to 1150 watts
 - "Soft Start" design reduces fixture inrush current
 - Unit may be installed up to 1,000 feet from controlled fixture(s)
 - Lumen output from fixture is 100% of nominal
 - Unique design eliminates compatibility problems with LED drivers as well as fluorescent and induction ballasts
 - Compatible with dimming ballasts
 - Normally-ON and/or Normally-OFF load output
 - Provisions for local switching capability - Always on during emergency conditions regardless of local switch position
 - Emergency fixtures can be ON, OFF or SWITCHED
 - Solid-state, line latched low voltage disconnect provides protection against battery deep discharge
 - Long life, maintenance-free lead-calcium battery
 - Momentary test switch
 - AC-ON, Charge-ON and Inverter-ON LED indicators
- * Consult factory for compatibility for other lamp types

WIRING

Connection to an unswitched AC circuit is required by the NEC. Wiring access is provided for by conduit knockouts in the unit housing.

LOAD COMPATIBILITY

LPS model's clean, sinusoidal AC output will operate incandescent lamps as well as all common fluorescent, induction and LED lamp types. Consult factory for compatibility with all other lamp types.

Lighting loads are driven at 100% output for the entire emergency power cycle. This outstanding feature translates into greater occupant egress vision and safety.

SYSTEM OPTIONS ⁽¹⁾⁽²⁾

ADD SUFFIX	DESCRIPTION
-OCBX (X = 1 to 6)	One to Six Output Breakers ⁽⁵⁾
-ICB	Input Breaker ⁽⁵⁾
-SP	Special Housing Color (specify)
-4AO	Adjustable Output/Dimmer Bypass ⁽³⁾⁽⁴⁾
-4C	Four Output Circuit Switching ⁽³⁾⁽⁴⁾
-SDT	Self-Testing/Self-Diagnostics ⁽³⁾

(1) Other options available. Consult factory.

(2) Some options may impact product UL listing. Consult factory.

(3) For more information, separate specification sheets are available on the -4AO, -4C and -SDT options. Consult factory

(4) Not available together

(5) Total number of Circuit breakers not to exceed six

GENERAL SPECIFICATIONS

MODEL NUMBER	INPUT/OUTPUT VOLTAGE	CAPACITY FOR 1-1/2 HRS. WATTS/VA	SYSTEM WEIGHT		SYSTEM EFFICIENCY (FULL LOAD)	NUMBER OF BATTERIES	NUMBER OF BATTERY STRINGS	BATTERY VOLTAGE (VDC)	BATTERY CURRENT (ADC)	AC INPUT CURRENT (MAX AMPS)		THERMAL OUTPUT (BTUs)		HOUSING DIMENSIONS		
			LBS.	KG.						120VAC	277 VAC	ON-LINE	EMERGENCY	LENGTH	HEIGHT	DEPTH
LPS-750	120/277 VAC	750/750	190	86.2	98 %	8	2	48	18.2	7.53	3.26	14	416	22.4"	25.1"	9.2"
LPS-950	120/277 VAC	950/950	222	100.7	98 %	10	2	60	18.2	8.45	3.66	18	484	22.4"	25.1"	9.2"
LPS-1150	120/277 VAC	1150/1150	254	115.2	98 %	12	2	72	18.2	10.2	4.42	22	535	22.4"	25.1"	9.2"

LPS Series Inverters

Higher wattage inverters

Emergency Power Systems

BATTERIES AND CHARGER

Battery

Battery: Sealed Lead Calcium (10 year life)

Battery Voltage: 48VDC for LPS-750, 60VDC for LPS-950, and 72VDC for LPS-1150 models

Runtime: 90-minutes standard - based on battery performance at (25°C). Other runtimes available, consult factory.

Battery Protection: Low Voltage Battery Disconnect protects the battery from being severely damaged by deep discharge during prolonged power failures. Reverse polarity, DC Overload and Short Circuit Protection provided by a DC input breaker and fuse.

Charger

Charger Type: Fully automatic, temperature compensated, dual-mode charger

Power Consumption (Charger Only):

53W maximum (4.3W in standby) for LPS-750 model

63W maximum (5.4W in standby) for LPS-950 model

73W maximum (6.7W in standby) for LPS-1150 model

Recharge Duty Cycle: Meets UL924 requirements

Battery Circuit Breaker: Also used as battery isolator

Controls: Momentary test switch, AC-ON, Charge-ON and Inverter-ON LED indicator lights

Safety Circuitry: AC Lockout prevents battery discharge prior to initial unit power-up.

Brownout Protection automatically switches the unit to emergency mode when utility voltage is significantly reduced

Environmental

Altitude: < 10,000 feet (3,000m) above sea level without derating.

Operating Temperature Range: 20°C to 30°C

NOTE: Optimum system performance between 20°C and 30°C; temperatures outside of this range will affect battery performance and life.

Relative Humidity: 95% non-condensing

OPERATION

Upon failure of the normal utility power the LPS unit is automatically turned on by a solid state switching circuit and provides a minimum of 90 minutes of emergency power to the connected load. Lumen output will be maintained at 100% of the lamp's rating throughout the entire duration.

A solid state low voltage disconnect circuit is used to protect the battery from being severely damaged by a deep discharge. When normal utility power is restored, the unit switches the load back to normal utility operation and the fully automatic, temperature compensated, dual mode charger begins to restore the battery; bringing it to full charge within UL 924 specified parameters.

SYSTEM STATUS MONITORING PANEL



All LPS systems provide a monitoring panel on the front of the unit to show operating status at all times. The panel provides a test switch for user initiated system tests and a 3-LED array that provides an intuitive visual indication of unit readiness.

IMPROVED AESTHETICS

The LPS system's sinusoidal AC output design eliminates voltage drop and proximity concerns. This allows added flexibility in installation location as LPS units can be installed hundreds of feet from the units they power. This means LPS units to be located conveniently out of sight in closets or utility rooms without interrupting architectural aesthetics.

In lighting applications, no special or additional emergency fixtures are necessary. Simply designate and connect existing lighting fixtures, either interior or exterior, to the LPS unit for emergency operation eliminating the need for exposed, stand-alone emergency luminaires.

LPS SYSTEM ADVANTAGES

Compared to traditional discrete emergency lighting units, the LPS Series provides emergency illumination from a single power source resulting in lower maintenance overhead and routine testing expenses. LPS units lower installation costs by powering existing lighting fixtures during emergencies. And because connected fixtures are driven at full brilliancy, they provide far superior egress lighting and deliver improved occupant safety.

LPS Series Inverters Higher wattage inverters

Emergency Power Systems

SUGGESTED SPECIFICATIONS

An inverter system with sinusoidal output shall be supplied capable of powering any combination of lighting fixtures, including incandescent, fluorescent, induction and/or LED light sources without compatibility problems.

The system shall transfer in less than 1.0 second to reliably back up lighting fixtures without loss of illumination and operate any and all connected lighting fixtures at full lumen output during the complete 90-minute discharge cycle.

The input voltage shall be the same as the output voltage and shall be single phase 120/277 volts, 60 Hz. Output capacity will be (750W/750V) or (950W/950V) or (1150W/1150VA) for a minimum duration of 90 minutes

The design shall be a standby, off-line inverter with on-line efficiency of 98%; on-line double conversion UPS systems shall not be considered acceptable alternatives. LPS System output shall be a PWM generated sine wave with less than 3% total harmonic distortion with Soft Start design reducing fixture inrush current. The system shall also provide short circuit and overload protection as standard.

An intuitive three LED display shall provide system operational information at a glance and alert user to any malfunction in system performance. Authorized maintenance personnel shall have access to the system's controls while being protected from any live exposed connections.

Protective devices shall include AC Line fuses, DC input breaker and a DC input fuse. The entire LPS system, including batteries, shall be incorporated into compact cabinetry which shall have provisions for surface mounting.

System shall be capable of providing up to 4 switch bypass circuits, adjustable output with 2.5 to 10 volt dimmer bypass and self-test/self-diagnostics, were necessary

System shall utilize a sealed lead calcium battery with a 10 year design life. The charger shall be temperature compensated, dual mode type, and recharge the batteries as per UL924 guidelines. Entire system shall be tested, approved, and labeled to UL924 Emergency Lighting and Power Systems standards.

STANDARD WIRING DIAGRAMS

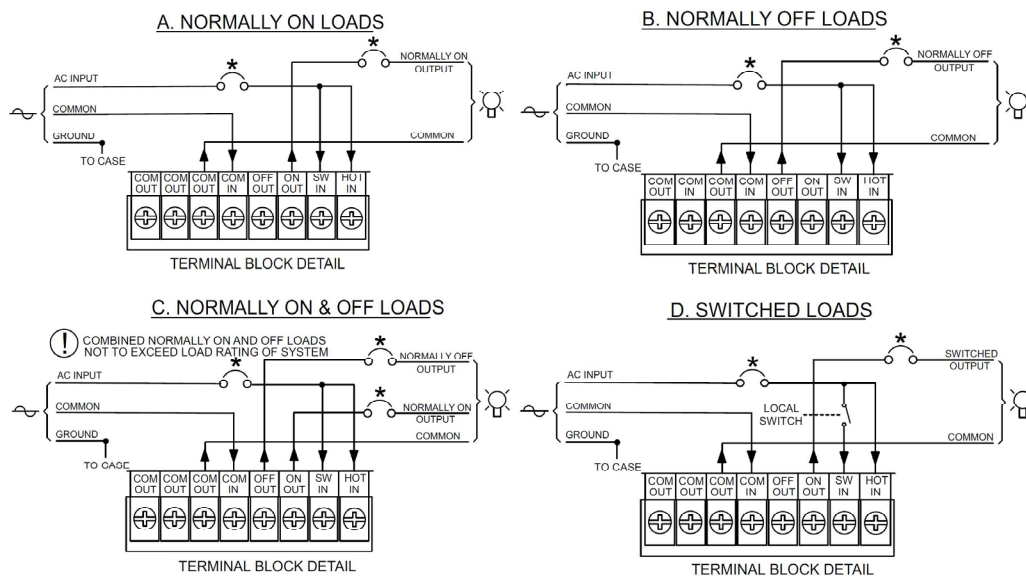

- NOTES:**
- ⚡ INPUT SUPPLY FROM UNSWITCHED UTILITY RATED 20 AMPS MAXIMUM.
 - 💡 OUTPUT(S) TO LIGHTING LOADS
 - * AVAILABLE WITHIN UNIT AS OPTION

VOLTAGE SELECTION DETAIL

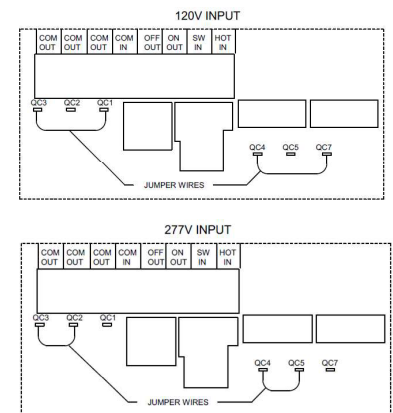

NOTE:
 Factory terminated jumper wires are provided with LPS Systems for making user selected input/output voltage connections.



Warranty

Americanlite® is pleased to provide a 5 year limited warranty covering the Emergency LED drivers on this catalogue. Americanlite® warrants that the Emergency LED drivers comply with Americanlite®'s published specifications and are free from defects in materials and workmanship.

All our equipment is CE, TUV, FCC or UL approved and manufactured with approved components. Americanlite® reserves the right to change or improve the design or components of any of its products due to parts availability or changes in standards, without assuming any obligation to modify any product previously manufactured and without notice. All equipment is tested and inspected before shipment.

This warranty is void if the product is operated outside of its normal operating conditions. The foregoing warranty does not apply to failures caused by acts of God or as a result of any abuse, misuse, abnormal use, or use in violation of any applicable standard, code or instructions for use in installations, including, but not limited to, those contained in the Standards for the International Electrotechnical Commission. Americanlite® reserves and has the right to examine failed fixtures to determine the cause of failure, excessive lumen depreciation and patterns of usage.